

MT TYPE

HIGH SPEED CONTINUOUS SPINNING TYPE

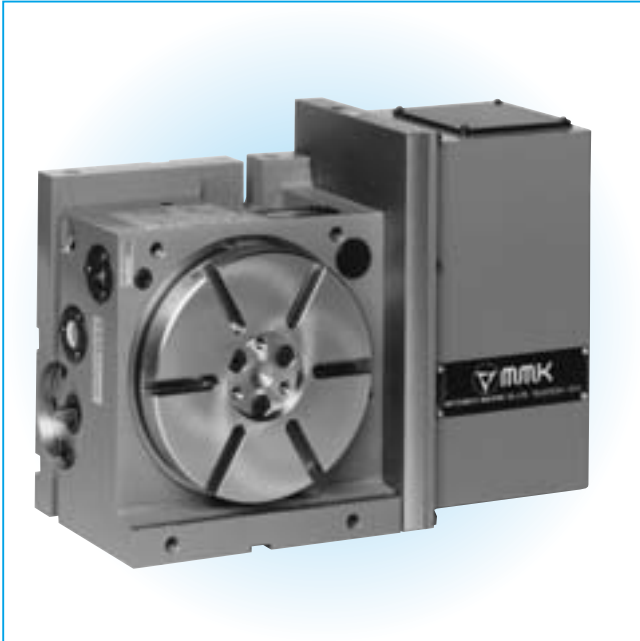

PRECISION SPIN-TABLE

*HIGH SPEED SPINNING TABLE
FOR GRINDING CENTER*

**MT 200-1
MT 200-3
MT 200-5
MT 320-3
MT 500-1**

SPECIFICATION

ITEMS	MODEL	MT200-1	MT200-3	MT200-5	MT320-3	MT500-1	
TABLE DIAMETER	mm	200	200	200	320	500	
CENTER HEIGHT IN VERTICAL	mm	140	140	140	210		
TABLE HEIGHT IN HORIZONTAL	mm		185	260	260	300	
OVERALL HEIGHT IN VERTICAL	mm	366	325	367	352	300	
THRU HOLE DIAMETER	mm				50		
WIDTH OF T-SLOT	mm(H8)	12	12	12	14	14	
WIDTH OF GUIDE BLOCK	mm(h7)	18	18	18	18	18	
MOTOR		2KW	750W	750W	22/2000	2.2KW	
INDEXING ACCURACY							
GEAR RATIO		1/20	1/10	1/6	1/6	1/30.05	
MAX. R.P.M	r.p.m.	100	300	500	300	100	
CLAMPING FORCE	N-m	216	216	216	294	421	
	kg-m	22	22	22	30	43	
HYDRAULIC PRESSURE	MPa	5	5	5	5	5	
	kg/cm ²	50	50	50	50	50	
PERMISSIBLE LOAD	HORIZONTAL	kg		45	20	90	670
	VERTICAL	kg	20	20	15	40	
GRINDING FORCE	N-m	122.5	8.8	11.8	100	17.6	
	kg-m	12.5	0.9	1.2	10.2	1.8	
	r.p.m.	at 100	at 300	at 500	at 100	at 100	
WEIGHT	kg	94	80	95	250	550	

MT200-1

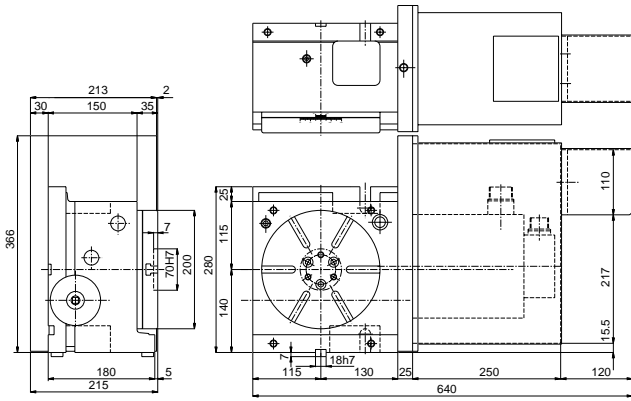

MT200-3

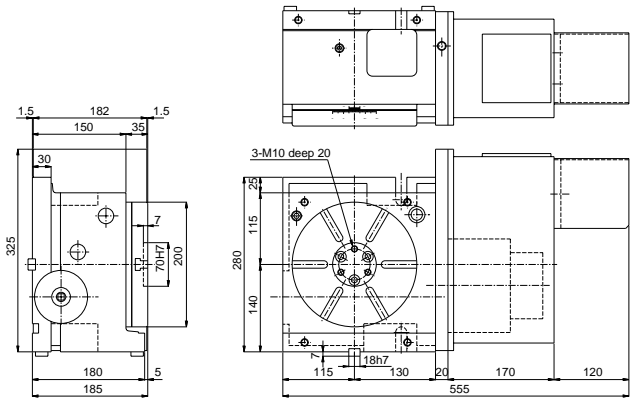

MT200-5

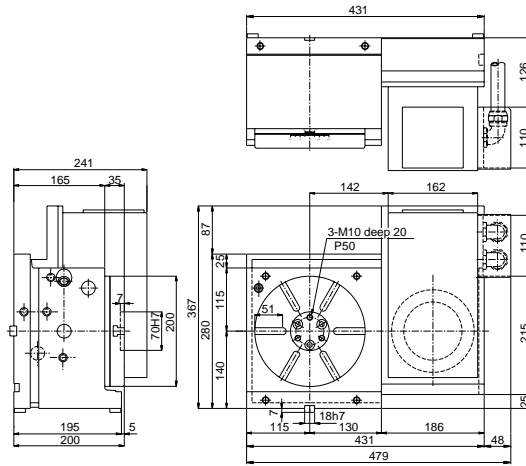

MT320-3

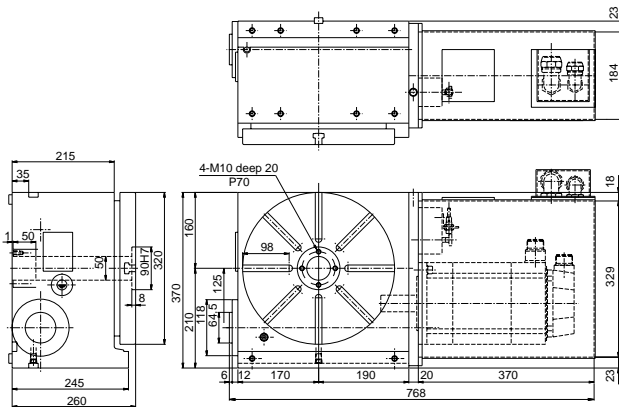

MT500-1

