

MDE TYPE

COMPLETE-SEALED TYPE

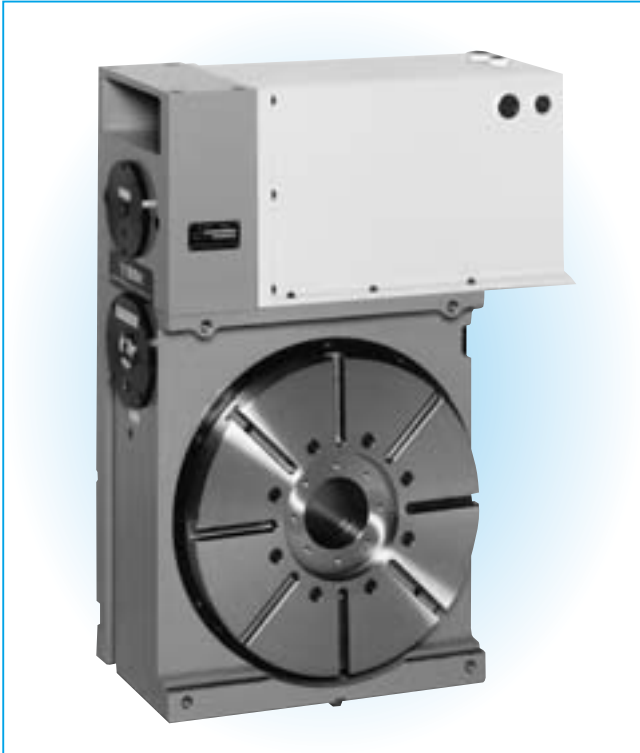

NC ROTARY TABLE FOR EDM

MDE 150R(L)
MDE 211R(L)
MDE 400R(L)
MDE 630R(L)

SPECIFICATION

ITEMS	MODEL		MDE150R(L)	MDE211R(L)	MDE400R(L)	MDE630R(L)
TABLE DIAMETER		mm	150	210	400	600
CENTER HEIGHT IN VERTICAL		mm	120	165	235	400
TABLE HEIGHT IN HORIZONTAL		mm	145	215	250	
OVERALL HEIGHT IN VERTICAL		mm	418	620	780	1110
THRU HOLE DIAMETER		mm	20	43	90	210
WIDTH OF T-SLOT		mm		12	14	18
WIDTH OF GUIDE BLOCK		mm(h7)	14	18	18	
MOTOR			(2)	(6)	(12)	(22)
GEAR RATIO			1/90	1/180	1/180	1/360
MAX. R.P.M		r.p.m.	2.5	11	5.5	5.5
MIN. INDEXING UNIT		degree	0.001	0.001	0.001	0.001
INDEXING ACCURACY		sec	60	20	14	12
REPEATABILITY		sec	± 3	± 2	± 2	± 2
PERMISSIBLE LOAD	HORIZONTAL	kg	80	200	500	
	VERTICAL	kg	50	100	350	800
MAX MACHINING FORCE		N·m	343	490	1470	3136
		kg·m	35	50	150	320
WEIGHT		kg	50	130	290	1100

MDE150R

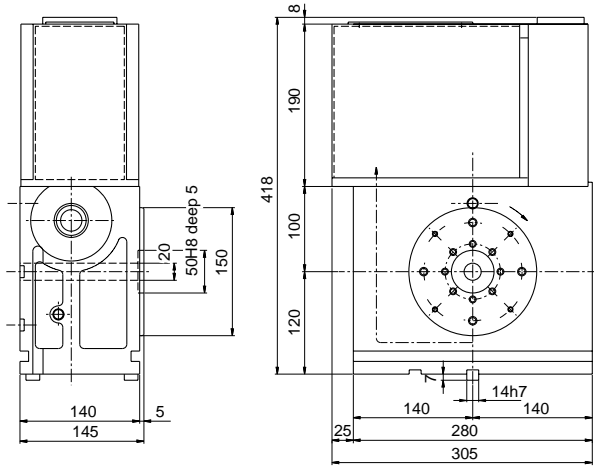

MDE211R

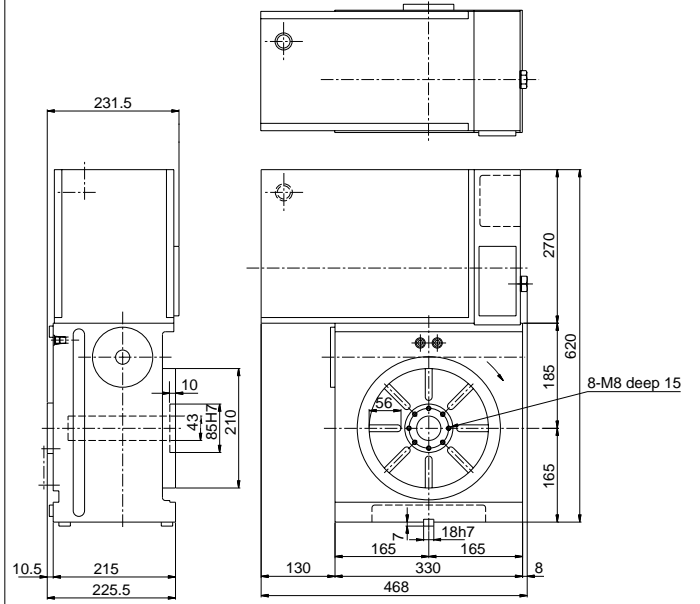

MDE400L

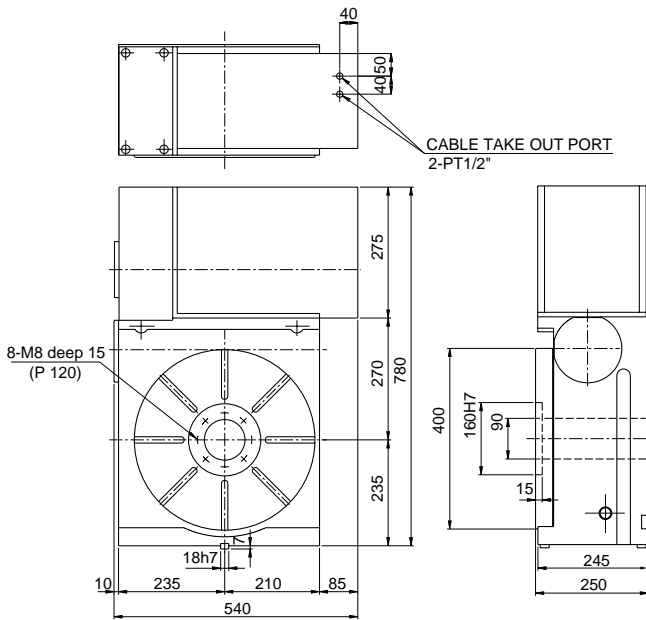

MDE630R

